

CONTRACT N°: RII3-CT-2004-506065

ISSUE CERTIFICATE

EURONS

EUROpean Nuclear Structure research

Activity JRA07 : ISIBHI

Identification: D-J07-b

Revision: 0

ISIBHI

Final report and prototype description of A-PHOENIX

Dissemination level: *PU*Issued by: *LPSC*Reference: *EURONS- D-J07-b*Status: *Final***Summary:**

This document presents the progress of the A-PHOENIX prototyping performed during the contract. The design of A-phoenix is recalled, steps of construction are shown. The status of the commissioning at 18 GHz is presented. The research activity directed by NIPNE on the effect of metallic dielectric structures on ECR plasma is also proposed in the document.

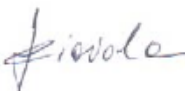
23.12.2008	T.Thuillier LPSC	G. Ciavolla INFN	Alex C. Mueller, CNRS
			
DATE	RESPONSIBLE Name/Company Signature	WP LEADER Name/Company Signature	COORDINATOR Name/Company Signature

1 Conceptual studies and industrial Design

1.1 Minimum-|B| Magnetic structure design

A-PHOENIX is a compact hybrid Electronic Cyclotronic Resonance Ion Source (ECRIS) of new generation. The magnetic field necessary to confine the plasma is created by a large size permanent magnet hexapole and a set of solenoids. The two external solenoids are made up with High Temperature Superconductors (HTS), a third central one, is a classical room temperature copper coil. The Solenoids are surrounded with a pure iron shield in order to minimize the magnetic fringe field and maximize the magnetic flux intensity in the plasma chamber volume, location of the ECR plasma generation. The magnetic structure of the A-PHOENIX geometry has been studied and optimized with the 3 dimensional (3D) RADIA software (partial copyright of Mathematica). A View of the simulation is proposed on figures 1.1.a and 1.1.b.

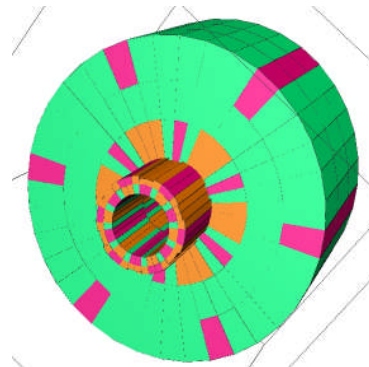
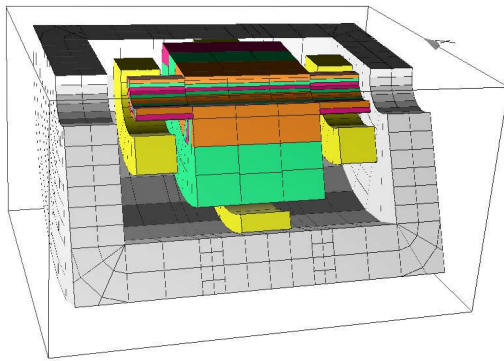

Figure 1.1.a : 3D view of A-PHOENIX magnetic structure as simulated with RADIA

Figure 1.1.b : Detail of the magnets composing the hexapole

a. Axial magnetic field

The axial magnetic mirror of A-PHOENIX is established by 3 Solenoids. The two High Temperature Superconducting Coils have been ordered former to the 6th PCRD to Space Cryomagnetism LTD. Figure 2.a shows a photo of the two assembled HTS Coils taken at Culham (UK). Each HTS Solenoid can deliver 3 Tesla in a free inner diameter of 120 mm. During magnetic design optimisation, a third room temperature coil has been added between the two HTS coils. Its function is to perform a fine tuning of the magnetic minimum (± 0.2 T corrections) at the centre of the axial mirror trap. A typical axial magnetic mirror profile is plotted in figure 1.2.b.



Figure 1.2.a : Photo of the two HTS Coils Cryostats built at Culham.

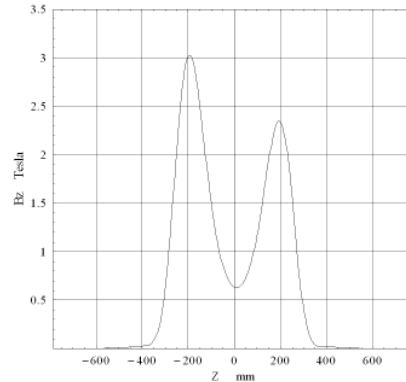

Figure 1.2.b : Typical axial magnetic mirror profile of A-PHOENIX

b. Hexapole design

It is the first time in the world that such a large hexapole will be assembled; the magnetic intensity that it will deliver has never been reached so far before using permanent magnets. The hexapole is composed of 3 parts. The first part is the central hexapole; which is 24 cm long with respectively 72 and 400 mm inner and outer diameters. It is made of three concentric layers of permanent magnets. The two other hexapoles are smaller and located at each extremity of the main hexapole, just under the two HTS solenoids (see figure 1.1.a). Their inner and outer diameters are respectively 72 and 112 mm. A careful precise simulation study has been performed to optimize the magnetic induction produced by the hexapole in the ECRIS plasma chamber, taking into account the magnetic load induced in each local magnet. Forces on magnets have been calculated to safely size safely mechanical parts. Simulation shows that the hexapole magnetic induction should reach 2 Tesla at the 72 mm inner diameter. In the plasma chamber wall due to the space necessary for cooling, the magnetic induction is still at 1.6 Tesla.

c. Special plasma chamber design

In order to increase the radial magnetic confinement, several innovative prototypes of plasma chambers have been simulated that will include thin pure iron plates to locally boost the magnetic field from 1.6 (standard) up to 2.1 Tesla Figure 3a. This technology is derived from the Modified Magnetic Profile Structure (MMPS) developed at Jyväskylä (Finland). Calculations to size the iron geometry effect have been cross-checked by 2D program by the Jyväskylä team. Figure 3b displays the magnetic boost generated by the MMPS plasma chamber for several iron design.

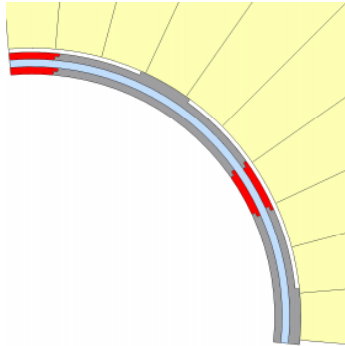

Figure 1.3.a : sketch of the plasma chamber wall cross-section(gray). The thin iron plates are in red, while permanent magnets appears in yellow.

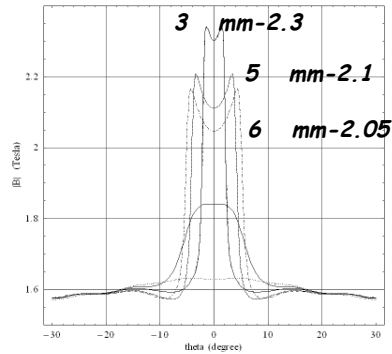

Figure 1.3.b : Simulated magnetic induction increase in the plasma chamber as a function of the iron insert geometry

1.2 A-PHOENIX Mechanical Design and status of construction

The 3D Computer Assisted Design (CAD) was made with CATIA software at LPSC. The 3D design was completed in May 2006 and the last mechanical part drawing was provided in the end of September 2006. Details of final A-PHOENIX CAD are proposed on figures 1.4.a and 1.4.b.

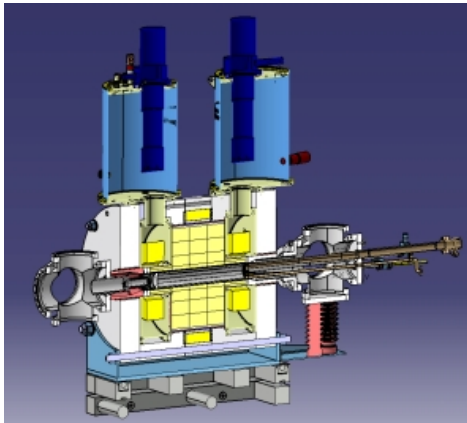

Figure 1.4.a : 3D View of A-PHOENIX as designed with CATIA

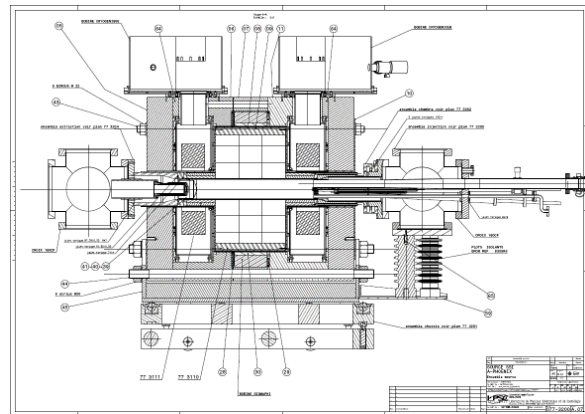

Figure 1.4.b : A-PHOENIX final detailed drawing cross-section

Hexapole assembly

A first step has consisted to design the heavy tools dedicated to build up the hexapole. These tools have been mainly machined at LPSC workshop in the end of 2005. The metallic cylinder holding the centre hexapole magnet can be seen in figure 1.5.a, filled up with brass false-magnets which will help for the magnet positioning and

mounting. The final assembly of the main hexapole will occur in December 2006. The two smaller lateral hexapole have been built during summer 2006, one of them is photographed on figure 1.5.b.



Figure 1.5.a : Centre hexapole cylinder which will contain the permanent magnets. At this stage, it is filled with brass mechanical parts that will help for final magnet assembly.



Figure 1.5.b : lateral hexapole fitted with permanent magnets

Final hexapole assembly will be done in January 2007.

Ion Extraction design

A first ion extraction system was designed, built and tested at LPSC during spring and summer 2006. It is composed with 4 electrodes having respectively the potential 60 kV, 0, -2.5, 0 kV. It was the first time at LPSC that such an extraction system was tested; an increase of the current extracted of 10 % has been noticed when using such extraction system.

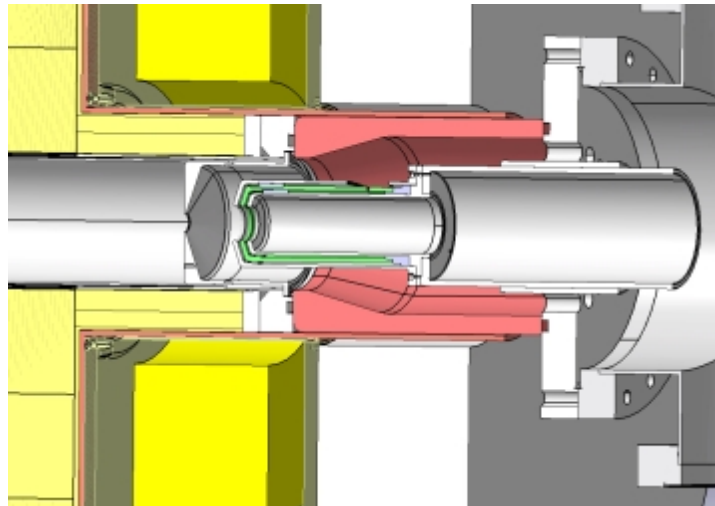

Figure 1.6: extraction system designed at LPSC.
Negative electrode appears in green.

HTS Coils Electronics

The LPSC has taken the responsibility to design and build the two electronic systems dedicated to secure the HTS Coils against quench effects. These systems are mandatory for HTS safe behaviour. Their design was achieved in February 2006 and drawings of the systems were approved by Space cryomagnetics LTD (who will deliver the HTS Coils in their Cryostats). The two quench-detection systems were completed in October 2006 and a photo of them is proposed in figure 1.7.a. Reception tests of the HTS Coils at Space Cryomagnetics have been performed during week 51 of 2006 (see figure 1.7.b). The final shipping of the coils to LPSC was achieved in March 2007.



Figure 7.a : Quench detection electronic for HTS Coil 1

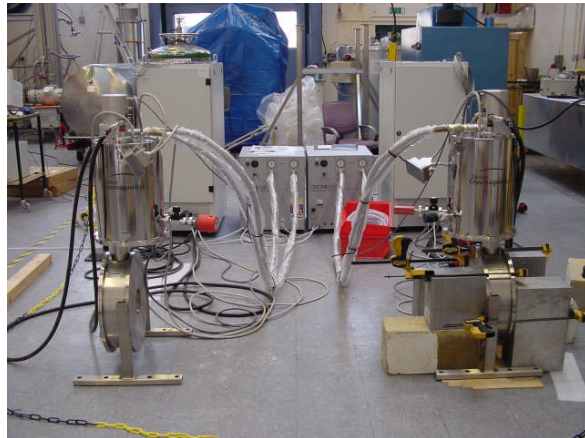

Figure 7.b : Test reception of the HTS coils in UK

2. Ion Source Assembly

2.1 Hexapole Assembly

The large permanent hexapole of A-PHOENIX was mounted during the spring 2007. As expected, and feared, the task was difficult and unexpected events occurred during the assembly (ungluing of some magnets). Thanks to the know how of the lab on hexapole mounting, it was possible to go through the difficulty and finish the job in april 2007. The magnetic field inside the structure was measured to be nominal with respect to the simulation.

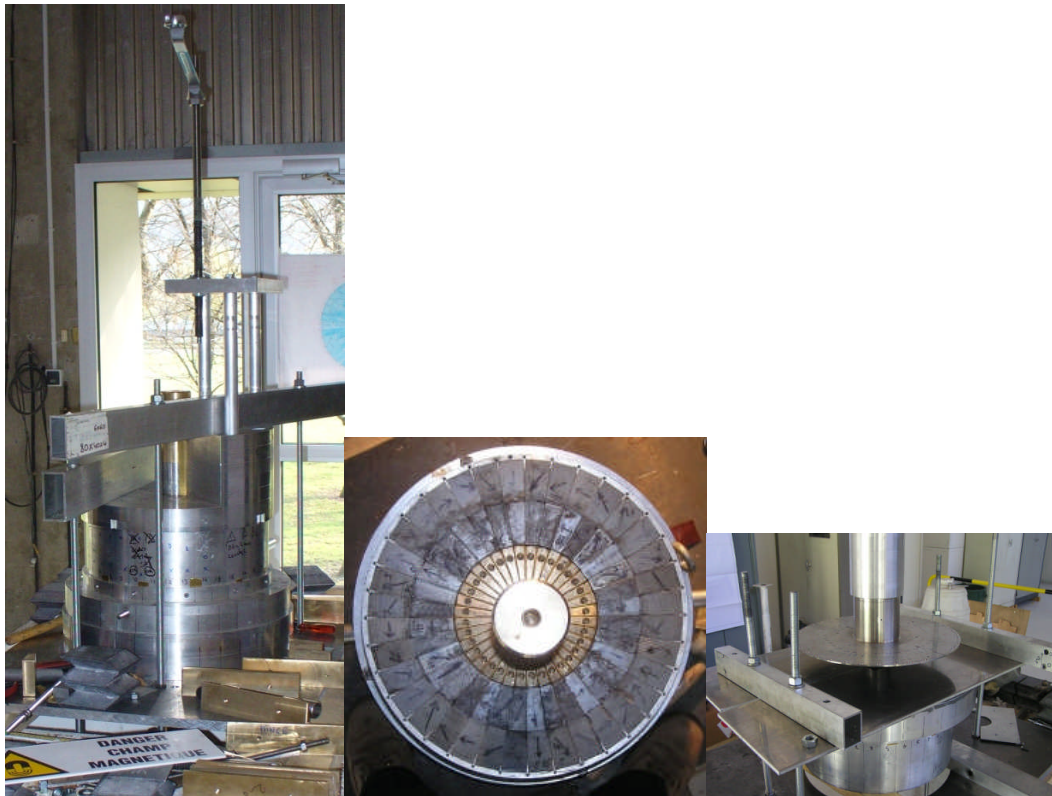

Figure 2.1: **Left** : press system to mount magnets safely. **Center** : Intermediate step of the mounting ; 2 magnets layers fitted in the structure ; the inner layer is still composed of brass parts that hold magnetic forces. **Right** : final assembly of the lateral hexapoles that close the large permanent magnet cylinder on both side.

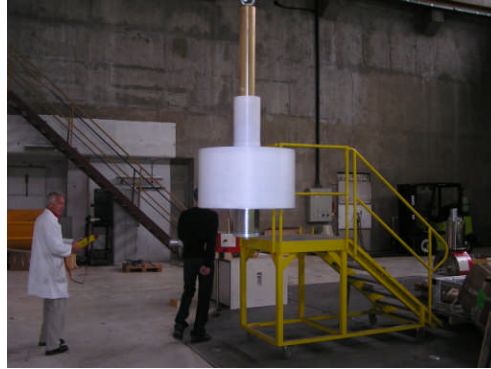

Figure 2.2: Hexapole finished and covered with one half of its High voltage polymer insulator.

2.2 ECRIS magnetic structure assembly

The two A-PHOENIX HTS Coils were delivered at the lab in march 2007. They have then been inserted in the iron yoke helped with a crane. The iron has several functions : increase magnetic field in the ECRIS, shield the magnetic field for surrounding equipments, and hold mechanically the coils to prevent any move due to the high magnetic fields.



Figure 2.3: HTS Coils in their cryostats, surrounded with their iron yoke.

The ECRIS assembly was done with a crane, since the overall weight is ~1,4 Tons. Elements were stacked vertically one after the other.

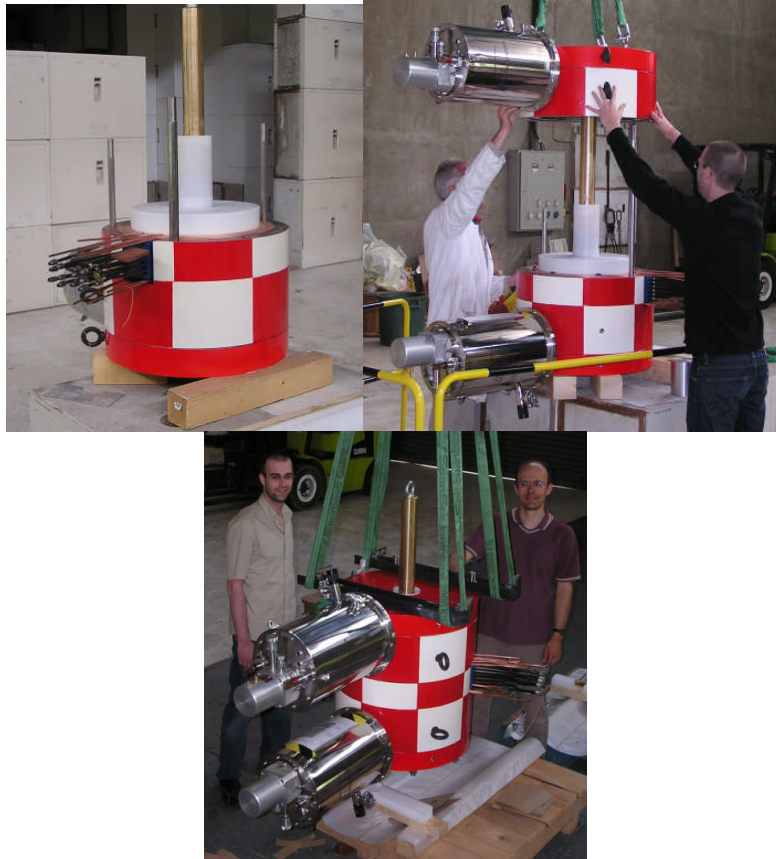

Figure 2.4: Left : Center copper coil (blue) stacked on the first HTS Coil, the hexapole is now included in the center (white). Center : second HTS coil being stacked. Right : ECRIS completed

2.3 Plasma chamber and high voltage assembly

The plasma chamber is introduced by the rear part of the ECRIS. It is centered by the inner radius of the hexapole itself. The first plasma chamber is made up with stainless steel (316 L).

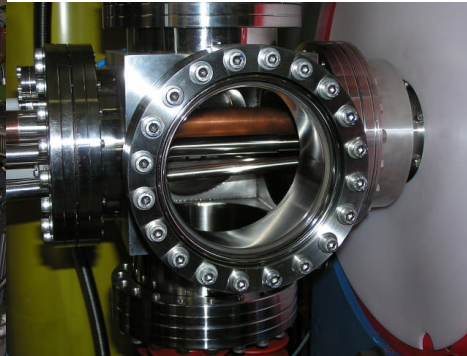
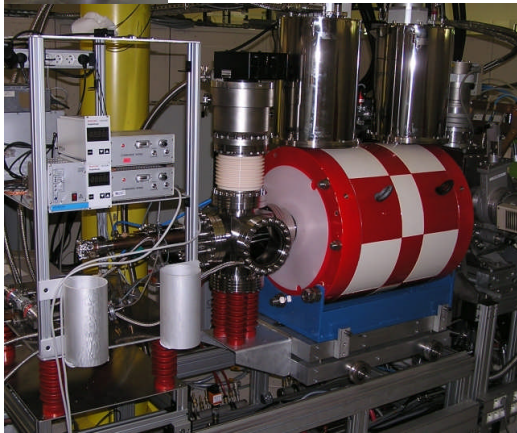

Figure 2.5: Left : plasma chamber. Center : photo of A-PHOENIX. Right : zoom on the UHV cross window.

The injection UHV 160 CF cross is mounted on 60 kV insulator (red corrugated parts on photos) and fixed directly to the plasma chamber. Then the injection system visible in the two photos below is screwed to the cross.

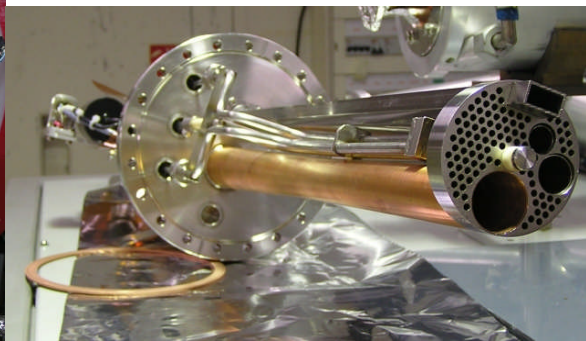
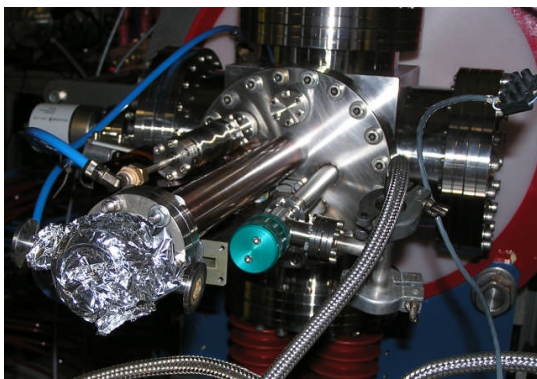

Figure 2.6: Left: injection flange seen from the rear of the ECRIS. Right: Injection flange seen from the other side : this parts is introduced in the plasma chamber.

One can see the 28 GHz oversized waveguide (copper cylinder), the WR 62 rectangular waveguide, the bias disk system, including a translation motor and water cooled tubes, then two tubes to bring gas and a metallic oven to the plasma chamber.

The high voltage platform is visible on the upper center photo. It contains all the equipments to be controlled at the ECRIS potential. The source and the high voltage platform are mounted on wheels to make maintenance and R&D modifications easier.

3. Commissioning of A-PHOENIX

3.1 Tests of the source at 18 GHz

The tests of the source heated with a 18 GHz klystron were performed with Argon gas. Rapidly, the beam intensity extracted from the source remained stuck around 200 μA of Argon 8+. The expected intensity for this charge state was at least 1 mA. The hypothesis of a bad microwave coupling was considered. The injection flange (under vacuum) located at the bottom of the plasma chamber was modified to add a RF gasket to suppress microwave leaks from this part. No effect was observed. The length of the 18 GHz waveguide under vacuum was modified several times to try to change the coupling of the RF to the plasma. A positive effect was observed. After a few weeks to reach good vacuum condition in the source, high RF power injection shown unexpected overheating of the wave guide under vacuum; the metallic coating of the wave guide cracked into pieces and get evaporated to the surrounding mechanical parts. After cleaning of the parts involved, new tests at high power (1 kW) showed unexpected overheating of the microwave pressure window. The ceramic of the pressure window became porous. A careful study of the mechanical parts around the pressure window enabled to find the origin of the problem. A waveguide discontinuity was observed under vacuum, right after the pressure window, of 0.1 mm thickness. This 0.1 mm space was an error of tolerance machining not detected during the mounting of the source. The RF could go though that space and was then reaching a small parasitic cavity of length sensibly equal to the RF wavelength. By adding some aluminum foil in this area, the microwave transmission was improved, along with the mean charge state of the plasma (with respect to previous situation).

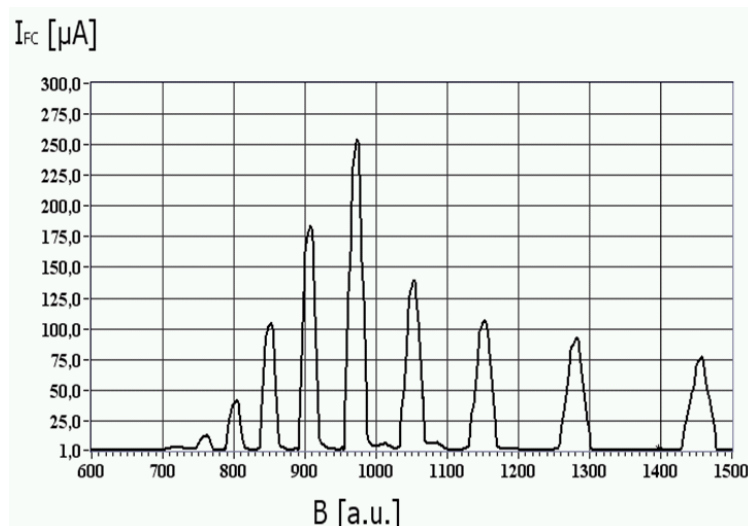

Figure 3.1 : Argon spectrum obtained while improving the microwave coupling.

A modification of the microwave transition from air to vacuum was then designed to get rid of the problem. A water cooling system was also added to the wave guide close to the

pressure window. Performances of the source then increased to reach 650 μA of argon 8+, giving new hope for the future. A new current limitation was reached at that level. The progress of the source commissioning is proposed on figure 3.2 as a function of time.

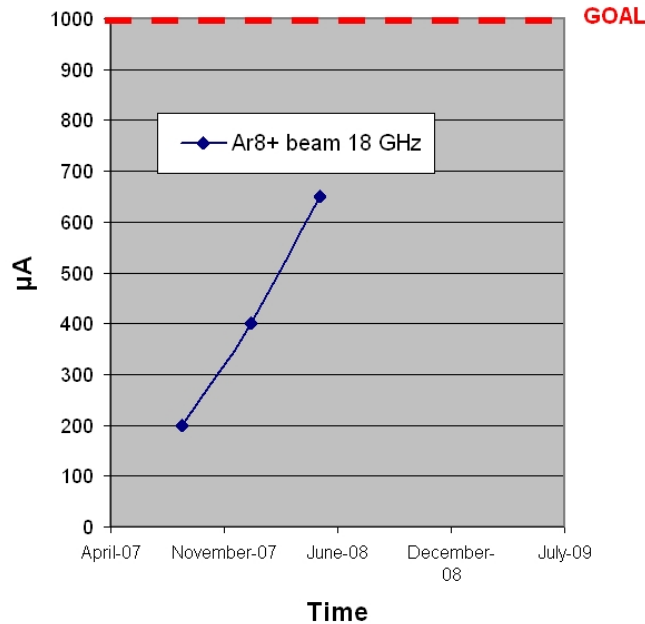

Figure 3.2 : progress of Ar8+ beam current extracted as a function of time (obtained thanks to microwave coupling improvement).

A careful study of other ion source parameters did not help (gas pressure, magnetic confinement, bias disk...). The last possible option for the current limitation was finally attributed to an accident that occurred at the beginning of the commissioning that we neglected as a first hypothesis. 500 W Microwave power was injected for 45 minutes in the source with insufficient water cooling.

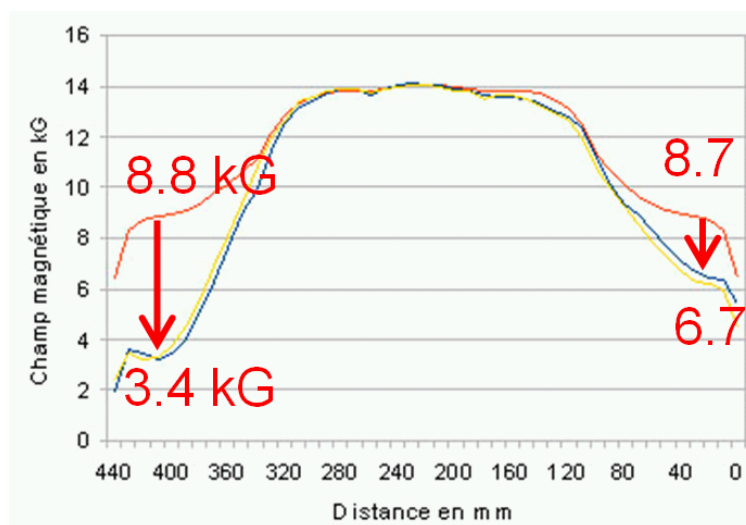

Figure 3.3: partial demagnetization of the hexapole after the accident (Raw datas)

A magnetic measurement has shown that some permanent magnets located near to the superconducting coils suffered of overheating and get partially demagnetized. The main central hexapole was controlled and fortunately did not suffer from the incident. The raw data magnetic measurements before and after the measurement are plotted on figure 3.3. New magnets have been purchased and experiments stopped, waiting for the hexapole to be fixed up.

3.2 R&D to prepare tests at 28 GHz

In parallel to the 18 GHz tests, in order to reach $B_r > 2$ Tesla radial confinement at the plasma chamber wall, mechanics R&D engineering was continued to try to find a confident technique to weld soft iron plates on the stainless steel plasma chamber outer and inner cylinders,. The geometry of the soft iron plates are drawn in blue and red on figure 3.4, along with the plasma chamber cylinders.

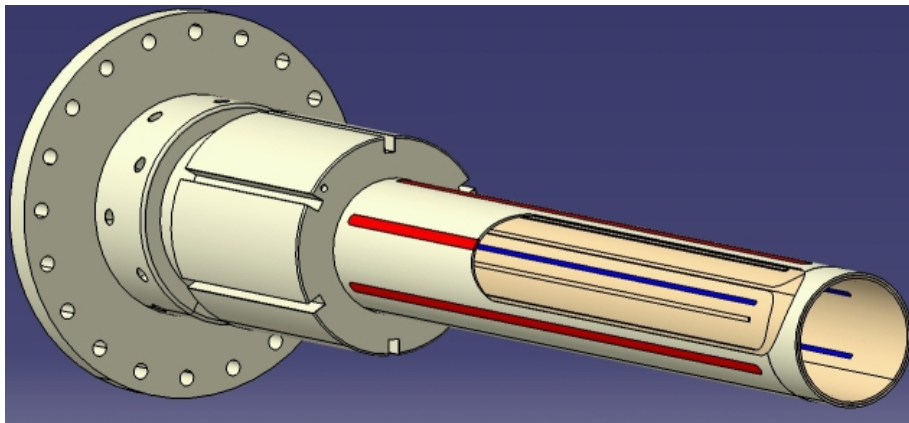

Figure 3.4: recall of the soft iron plates position in the plasma chamber body.

A first attempt was done at the SDMS company (St Romans, France). A fake plasma chamber was brought to them along with soft iron machined little plates. SDMS tried to weld the soft iron in a high temperature oven ($\sim 1100^\circ\text{C}$) using Nickel based brazing technique. The fake chamber was unfortunately suffering from vacuum leaks. Observation with microscope shows that little braze cracks happened at the ends of the thin soft iron plate. The origin of those cracks is likely coming from the important difference of thermal dilatation properties of the two materials. A second attempt of brazing was decided at lower temperature. Even this attempt failed. Finally, the brazing technique solution was abandoned. A second technique was then studied using laser welding at the LRA Company (Fontanil, France).



Figure 3.5 : successful laser welding of the iron plate in the body of the plasma chamber

A preliminary test of feasibility was successfully passed by welding soft iron thin plate to 316L stainless steel. A second test on a fake plasma chamber with 3 soft iron plates was also successfully welded after several attempts. So the laser welding technique is operational. The final laser welding will be done on the real plasma chamber in the late December 2008. So unfortunately 28 GHz tests of the source will be done out of the present contract.

3.3 Collaborations with ISIBHI Partners

We have been honored to invite L. Schachter (NIPNE, Romania) and K. Stiebing (Univ. Frankfurt) at the LPSC in the frame of this contract. We have together tested a special dielectric layer in the PHOENIX source and study its ability to increase the ion charge state distribution of the plasma. Further tests with A-PHOENIX were planned for 2008 but unfortunately, the delay in the ion source planning did not allow to perform these very interesting tests. Results of the NIPNE research are presented in the next section.

We have also been honored to invite H.R. Kremers and S. Saminathan (KVI, Netherland). They came to LPSC in may 2008 to test the new pepper pot emittance meter they designed and built in the frame work of the ISIBHI collaboration. The emittance meter was installed at the end of A-PHOENIX beam line, very close to a home made LPSC Allison type emittance meter. These tests were very fruitful and enabled to validate both devices by cross checking their measurements. An example of Ne⁸⁺ emittance measured with the LPSC scanner is plotted on figure 3.6.

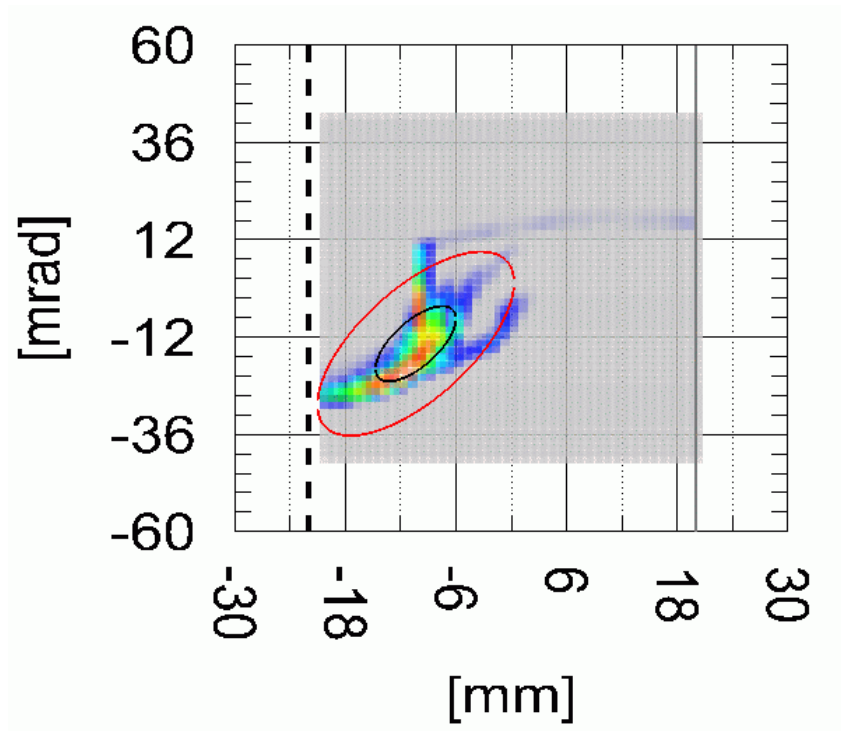

Figure 3.6: example of a Ne8+ vertical emittance measurement done with the LPSC scanner and cross checked with the KVI Pepper Pot.

4. Report on the study of Metal-Dielectric structure effect on ECRIS plasma

The main objective of the IFIN- HH in the ISIBHI activity was to study and test a special plasma chamber wall structure to improve ECRIS performances, leading to a possible application on new generation ECRIS like MS-ECRIS and A-PHOENIX. Special processed metal-dielectric structures (MD) were elaborated and their effect investigated in different ECR ion sources at 14 and 18 GHz:

- in Frankfurt/Main- Germany at the IKF ECRIS
- at the KVI 14 GHz ECRIS in Groningen
- at the 18 GHz ECRIS in INFN-Catania
- in the PHOENIX V2 18 GHz ECRIS in Grenoble-France.

The experiments proved that the method based on the physical processes in the ECRIS plasma chamber and in the boundary region of the extraction zone is efficient to improve ECRIS multi charged ion currents, without costly investments.

1. The experiment demonstrated that using a MD liner covering the inner radial walls of the plasma chamber in assembly with a similar structure installed at the extraction represents the best non conventional solution for a significant increase of the very high charge states of the source.(See Figure 4.1).
2. The experiment with a MD structure installed at the end electrodes confirmed that cutting the compensation wall currents increased the average confinement time and improved the ion production due to the partially restored ambipolarity (see figures 4.2, 4.3)
3. Also an aim of our experiments was to clarify if the resulted much higher output of the high charge state ions influenced the bremsstrahlung emission and which is the nature of this influence. In this spirit the effected experiments put in evidence the fundamental role of the plasma particles confinement on the level of the emitted radiation and the very positive effect performed by the use of the MD structures. In this context, the level of the X-ray emission affects the components life and imposes hard conditions of operation. Finally X-rays spectra and knowledge about the electron energy distribution are strong indicators for the producing capability of an ECRIS. The experiments indicate that the higher High Charge State (HCS) ion production is accompanied by a much lower X-rays emission.
4. The measurements indicate that the RF power may be reduced by factors of 2-3, to obtain the same output of argon HCS as in the standard source and thus to significant reduce the X-ray emission. (Fig.4.4, 4.5)
5. The MD method as enhancer of the HCS ion production is 3 times stronger than the gas mixing method.(Fig.4.6)

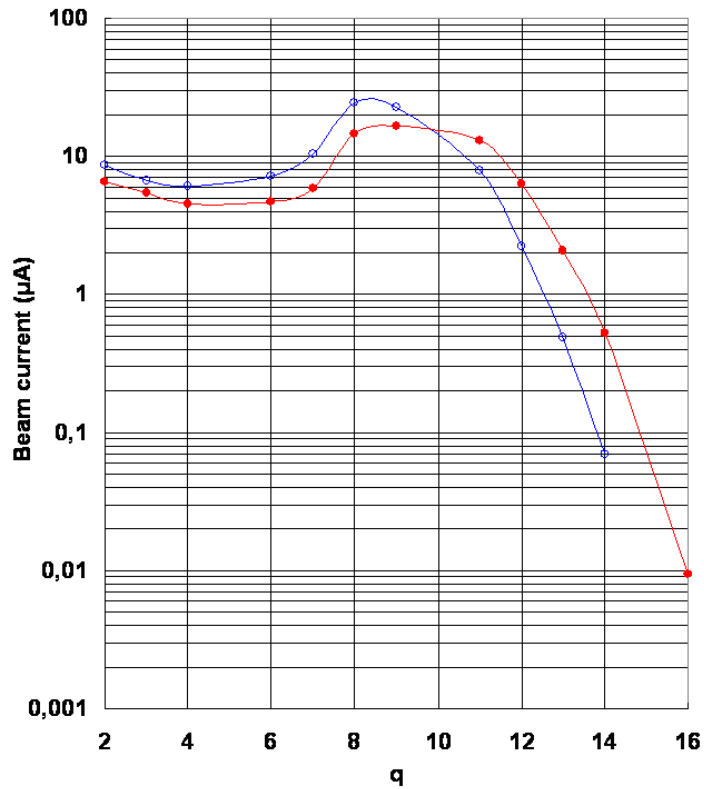

Figure 4.1: The CSD for the MD liner plus the MD structure at extraction (solid points) compared with the CSD for the standard mode of operation (open points). RF power of 600 W, optimization for Argon 12+.

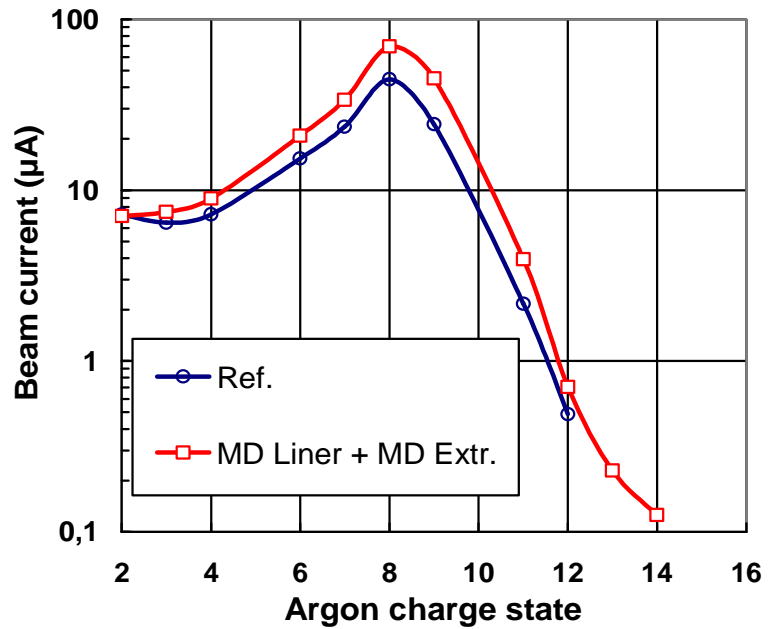

Figure 4.2: Effect of a combined MD liner + MD disk at plasma electrode at ion extraction side.

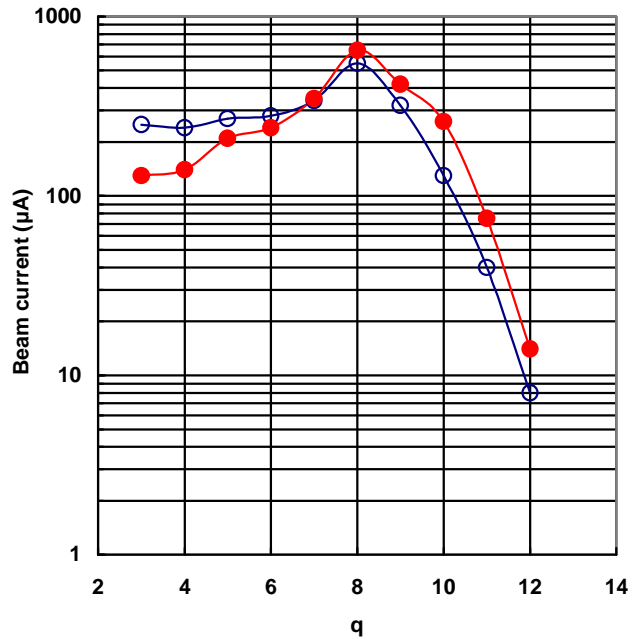

Figure 4.3: Charge States Distribution for Argon at the 18 GHz PHOENIX V2 ECRIS With MD extraction structure (red) and without (blue) in standard operation.

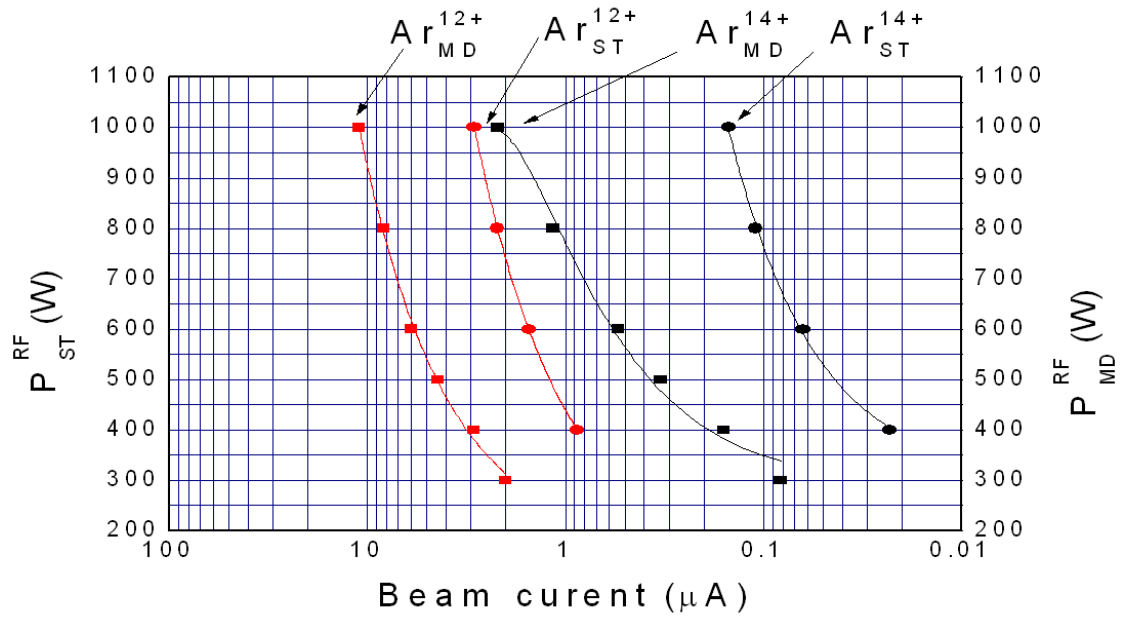

Figure 4.4: Evolution of Ar12+ and Ar14+ currents as a function of RF power with MD structure and without (ST in the plot).

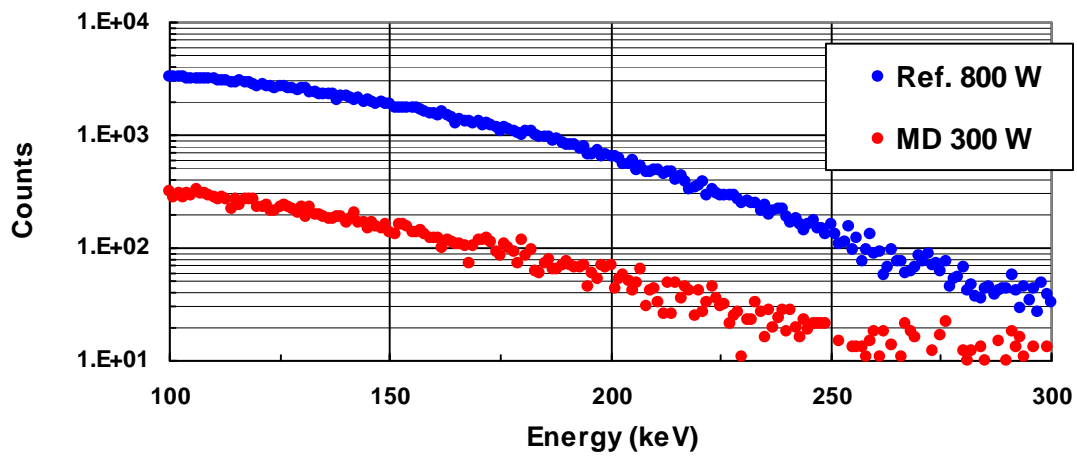

Figure 4.5: X-ray emission is reduced by a factor 10 for the source equipped with MD structures as compared to the “standard” (all stainless steel) source. (12+ optimization)

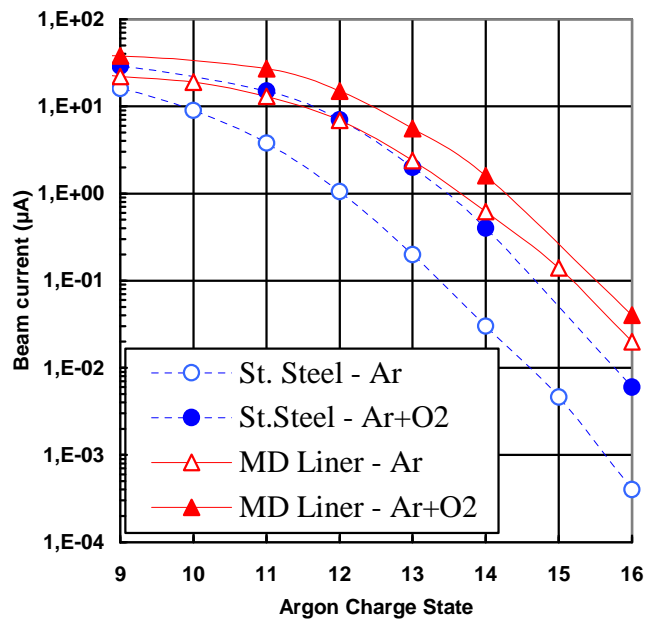

Figure 4.6: Comparison of HCS Argon production with different techniques. The best result is obtained with MD liner + gas mixing technique though the MD intrinsic effect is 3 times stronger as the GM effect.

5. List of publications during Eurons JRA7

1. T. Thuillier, T. Lamy, L. Latrasse, and J. Angot, First plasma of the A-PHOENIX electron cyclotron resonance ion source, *Rev. Sci. Instrum.* **79**, 02A330 (2008)
2. T. Thuillier, T. Lamy, P. Sortais, P. Suominen, O. Tarvainen, and H. Koivisto, A-PHOENIX, an electron cyclotron resonance ion source for the Spiral 2 facility, *Rev. Sci. Instrum.* **77**, 03A323 (2006)
3. H. R. Kremers, J. P. M. Beijers, S. Brandenburg, S. Saminathan, T. Thuillier, A comparison between an Allison scanner and the KVI-4D emittance meter, ECRIS '08 September 14- 18, 2008 Chicago, USA, JAcOW Website.
4. L. Schachter, S. Dobrescu, K. E. Stiebing, "Improved Ion Extraction from an Electron Cyclotron Resonance Ion Source by a Metal-Dielectric Extraction Electrode", *Rev. Sci. Instrum.* **77**, 03A905 (2006).
5. G. Ciavola, S. Gammino,, L. Schachter, S. Dobrescu, "Multipurpose Superconducting electron cyclotron resonance ion source (MS-ECRIS), The European Roadmap to 3rd Generation electron cyclotron resonance ion sources", *Rev. Sci. Instrum.* **77**, 03A303 (2006).
6. L. Schachter, K. E. Stiebing, S. Dobrescu, T. Thiullier, T. Lamy, The influence of Ambipolarity on Plasma Confinement and the Performance of ECRIS, *Rev.of Sci. Instrum.* **79**, 2, 02A329, 2008.
7. G. Ciavola, S. Gammino,L. Schachter, S. Dobrescu, K. Stiebing, A Status Report of the Multipurpose Superconducting Electron Cyclotron Resonance Ion Source, *Rev. Sci. Instrum.* **79**, 2 02A326.
8. L. Schachter, K. E. Stiebing, S. Dobrescu, Microwave Power Saving and Reduced Bremsstrahlung Emission for a High Charge State Ion Production in an ECRIS Equipped with MD Structures, ECRIS '08 September 14- 18, 2008 Chicago, USA, JAcOW Website.
9. L. Schachter, K. E. Stiebing, S. Dobrescu, Influence of the ECR Plasma Confinement on Reducing the Bremsstrahlung Production of an ECRIS with MD configuration(to be published)